

Gravity: Inverted Universal Globe Spin Theory – 10/28/2007

William D. Short, Balderston Drive, Exton PA, USA

Specific Topic: #16 original thought, looking at Inverted Systems of Rotation already evident on our Planet, and how Pressure is created through these Inverted Systems, Clockwise vs. Counterclockwise.

Exhibit: Section A – 23 – C

Date: 11/1/2007

Here we have systems that are all around us that already support and illustrate the active principles that are found in the “Inverted Universal Globe Spin Theory”. They demonstrate the creation of the “Coriolis Effect”, “Vortexes” and “Inward Directed Pulling Force”, which is just another way of looking at an “Inward Directed Center of Gravity”.

The first part illustrates the exact principle at play, where one system above is rotating in a different direction as the system on the ground, creating a vortex and a “falling pressure” towards the center of the storm system.

The second part of the illustration diagrams how two inverted systems that are rotating in opposing directions create at its center a downward pulling force.

In an “Inverted Universal Globe Spin Theory” system, you are applying these very principles. You are simply creating and maintaining an “Inward Directed Center of Gravity” by placing a smaller round object within a larger round object and whereby both find themselves traveling in opposing directions.

Copyright © All Rights Reserved, 2007

Gravity: Inverted Universal Globe Spin Theory – 10/28/2007

William D. Short, Balderston Drive, Exton PA, USA

Specific Topic: #16 original thought, looking at Inverted Systems of Rotation already evident on our Planet, and how Pressure is created through these Inverted Systems, Clockwise vs. Counterclockwise.

Exhibit: Section A – 23 – C

Date: 11/1/2007

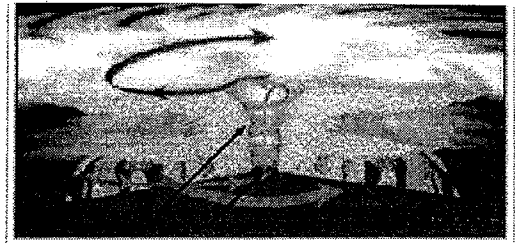
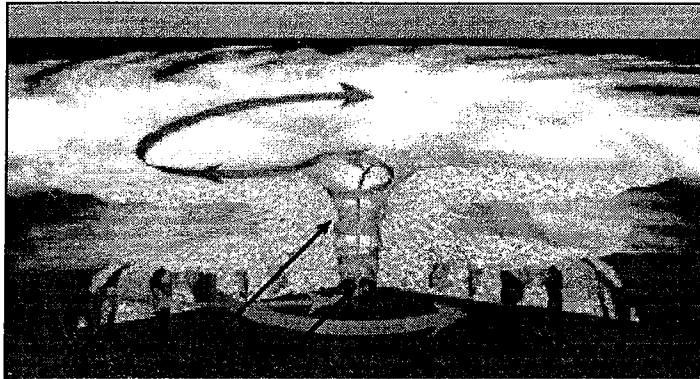

Structure of a tropical cyclone

11/13/2007

[http://upload.wikimedia.org/wikipedia/commons/a/a9/Hurricane structure graphic.jpg](http://upload.wikimedia.org/wikipedia/commons/a/a9/Hurricane_structure_graphic.jpg)

11/13/2007

Page 1 of 1

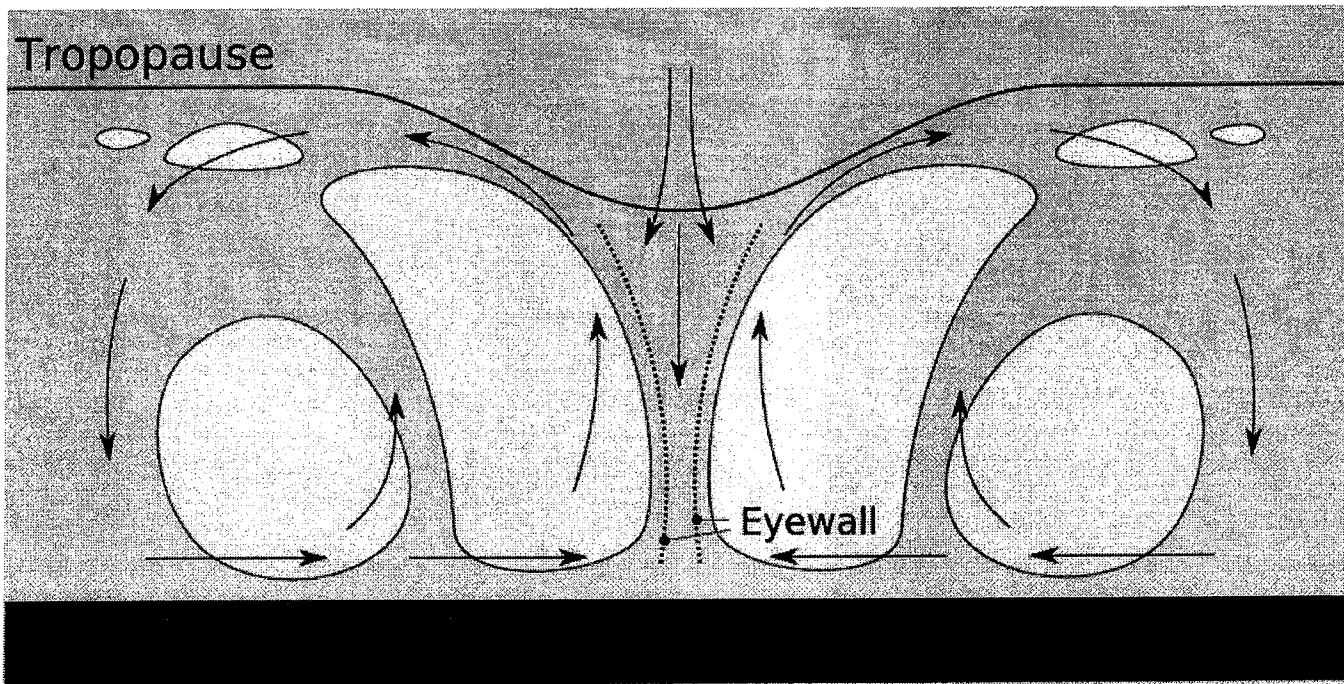

[http://upload.wikimedia.org/wikipedia/commons/thumb/f/fb/Hurricane profile.svg/800px...](http://upload.wikimedia.org/wikipedia/commons/thumb/f/fb/Hurricane_profile.svg/800px...) 11/13/2007

Eye and inner core

A strong tropical cyclone will harbor an area of sinking air at the center of circulation. If this area is strong enough, it can develop into an eye. Weather in the eye is normally calm and free of clouds, though

Gravity: Inverted Universal Globe Spin Theory – 10/28/2007

William D. Short, Balderston Drive, Exton PA, USA

Specific Topic: #17 original thought, looking at Coriolis Effect, a Phenomena, a Fact.

Exhibit: Section A – 23 – D

Date: 11/1/2007

This illustration explains what is commonly thought of as the cause of the “Coriolis Effect”. The common thought is that somehow “the winds” are the cause of the “Coriolis Effect”. This is not true, yes winds are involved in storms, but the “Coriolis Effect” takes place because of the way gravity is created and maintained.

As stated in Section A – 23 - A, if you look at Section B – 30 - A, the same thing takes place in Water Drains, which to date have not proven to show any wind activity.

The “Coriolis Effect” is in unison with the inversion that is taking place within our Earth’s rotation inside a rather large Universal Globe. Our storm patterns are factual evidence of the way gravity is working, as are Water Drains. They are both supportive evidence and proof of an “Inverted Universal Globe Spin Theory”.

These systems are following the lead of our gravitational rotation. Our gravity rotates “Counterclockwise” in our Northern Hemisphere” and “Clockwise in our “Southern Hemisphere”.

Copyright © All Rights Reserved, 2007

Gravity: Inverted Universal Globe Spin Theory – 10/28/2007

William D. Short, Balderston Drive, Exton PA, USA

Specific Topic: #17 original thought, looking at Coriolis Effect, a Phenomena, a Fact.

Exhibit: Section A – 23 – D

Date: 11/1/2007

Coriolis effect

The Earth's rotation imparts an acceleration known as the *Coriolis effect*, *Coriolis acceleration*, or colloquially, *Coriolis force*. This acceleration causes cyclonic systems to turn towards the poles in the absence of strong steering currents.^[36] The poleward portion of a tropical cyclone contains easterly winds, and the Coriolis effect pulls them slightly more poleward. The westerly winds on the equatorward portion of the cyclone pull slightly towards the equator, but, because the Coriolis effect weakens toward the equator, the net drag on the cyclone is poleward. Thus, tropical cyclones in the Northern Hemisphere usually turn north (before being blown east), and tropical cyclones in the Southern

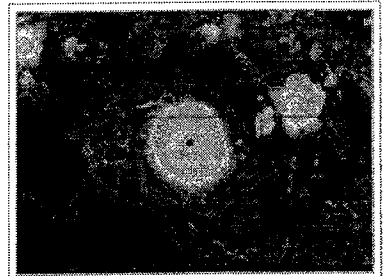

Infrared image of Cyclone Monica near peak intensity, showing clockwise rotation

http://en.wikipedia.org/wiki/Tropical_cyclone

11/13/2007

Gravity: Inverted Universal Globe Spin Theory – 10/28/2007

William D. Short, Balderston Drive, Exton PA, USA

Specific Topic: #18 original thought, looking at a blow up of a Cyclone, Coriolis Effect.

Exhibit: Section A – 23 – E

Date: 11/1/2007

This illustration is just a larger blown up picture of Section A – 23 - D, where the bands are clearly traveling from the East into the West in the Southern Hemisphere.

Copyright © All Rights Reserved, 2007

Gravity: Inverted Universal Globe Spin Theory – 10/28/2007

William D. Short, Balderston Drive, Exton PA, USA

Specific Topic: #18 original thought, looking at a blow up of a Cyclone, Coriolis Effect.

Exhibit: Section A – 23 – E

Date: 11/1/2007

Image:Cyclone Monica.gif - Wikipedia, the free encyclopedia

Page 1 of 2

Image:Cyclone Monica.gif

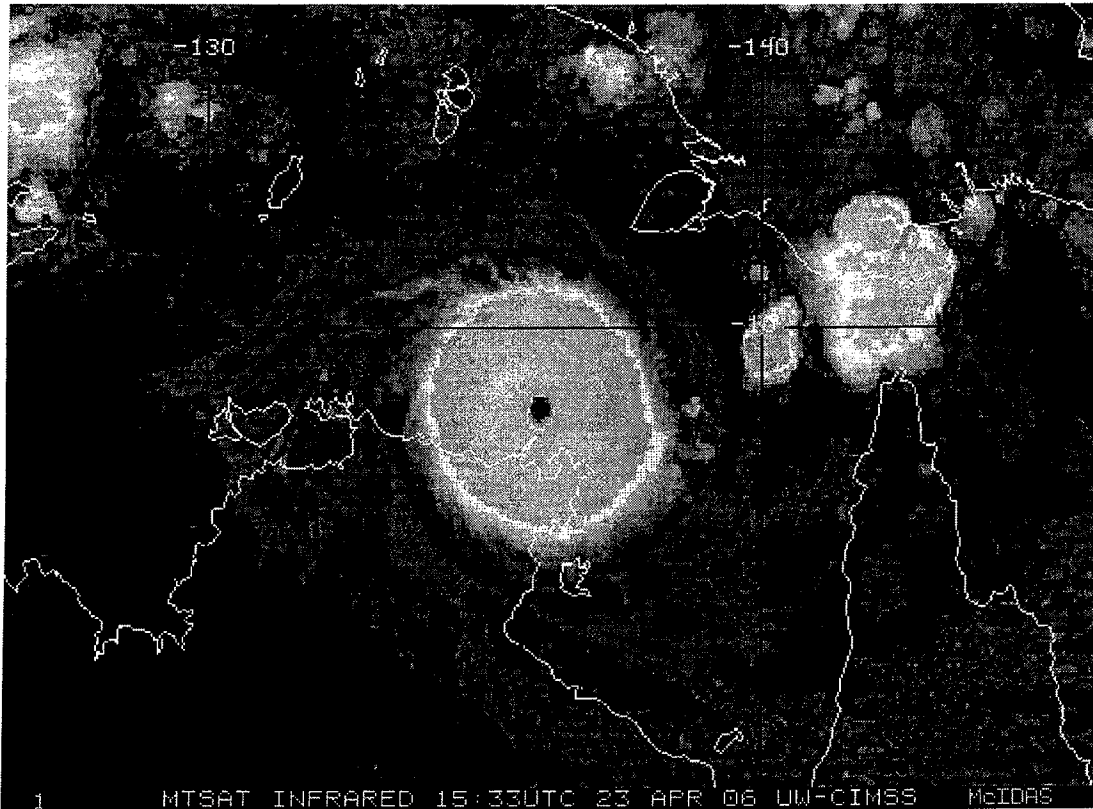

No higher resolution available.

Cyclone_Monica.gif (550 × 400 pixels, file size: 97 KB, MIME type: image/gif)

File links

The following pages on the English Wikipedia link to this file (pages on other projects are not listed):

- Talk:2005-06 Southern Hemisphere tropical cyclone season/January-April
- Cyclone Monica
- Tropical cyclone
- 2005-06 Australian region cyclone season

[http://en.wikipedia.org/wiki/Image:Cyclone Monica.gif](http://en.wikipedia.org/wiki/Image:Cyclone_Monica.gif)

11/13/2007

Gravity: Inverted Universal Globe Spin Theory – 10/28/2007

William D. Short, Balderston Drive, Exton PA, USA

Specific Topic: #19 original thought, Topical View of Inverted Spin Theory.

Exhibit: Section A – 28 – A

Date: 11/2/2007

This illustration shows the inversion that is taking place. It is not meant to be proportional in any way. It is a topographical view or picture, where North is located at the Earth's core if you will.

The Earth is fractal to the Universal Globe, or put in other words, we are in many ways a mirror image of a much larger object. We may not be found in the exact center of the Universe but our Equator or our Earth's West and East would be found to be parallel with the Universal Globe's West and East, as we would be spinning into it.

Copyright © All Rights Reserved, 2007

Gravity: Inverted Universal Globe Spin Theory - 10/28/2007

William D. Short, Balderston Drive, Exton PA, USA

Specific Topic: #19 original thought, Topical View of Inverted Spin Theory.

Exhibit: Section A - 28 - A

Date: 11/2/2007

INVERTED SPIN THEORY

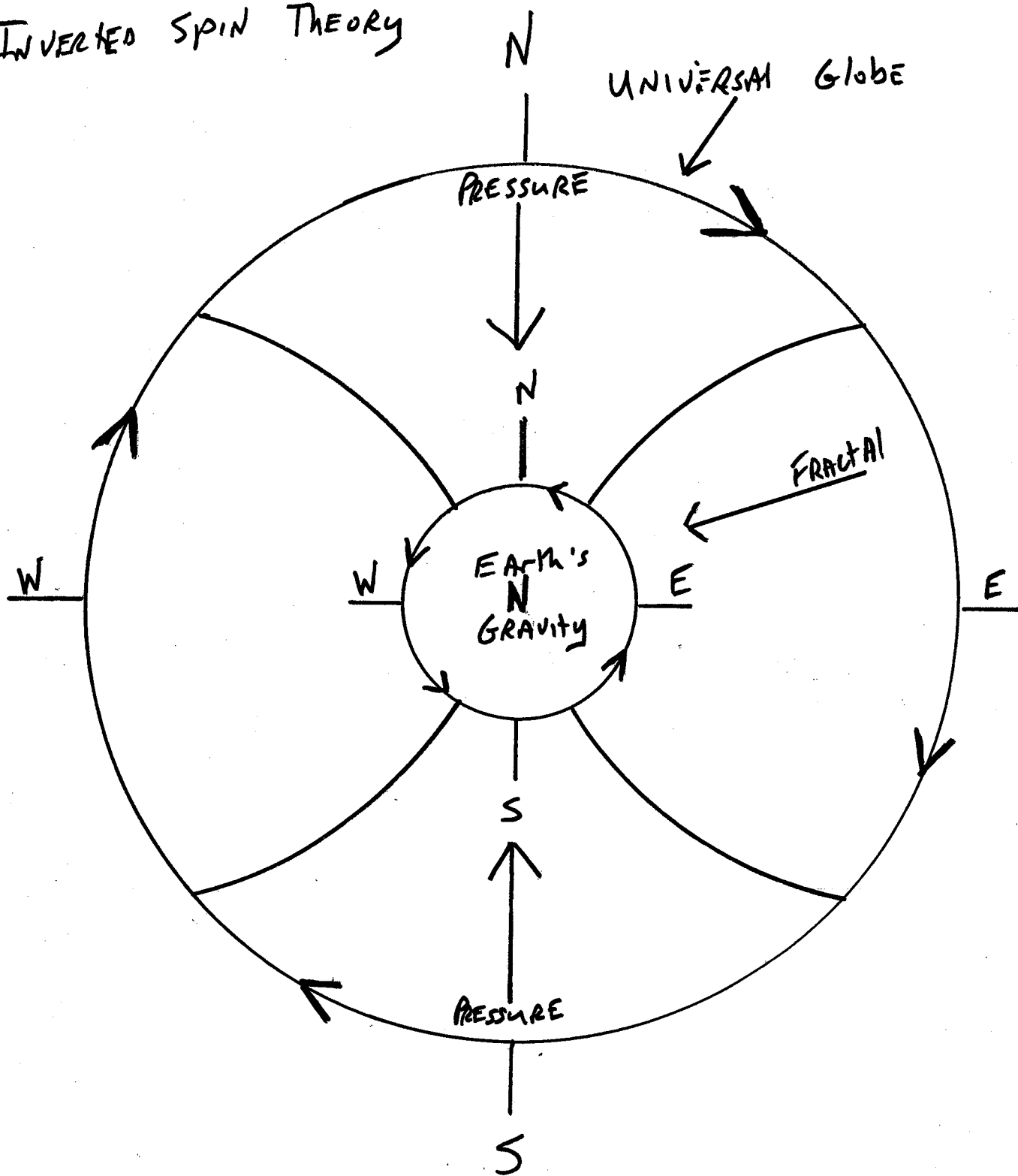

Gravity: Inverted Universal Globe Spin Theory – 10/28/2007

William D. Short, Balderston Drive, Exton PA, USA

Specific Topic: #20 original thought, Side View of Inverted Spin Theory.

Exhibit: Section A -28 – B

Date: 11/2/2007

This illustration is a Side View or a Picture of the inversion that is taking place. It is not meant to be proportional in any way.

The Universal Globe is traveling from the East into the West and the Earth which is inside this Universal Globe is traveling from the East into the West. Please see the “Global Spin Model” to examine this affect.

Copyright © All Rights Reserved, 2007

Gravity: Inverted Universal Globe Spin Theory – 10/28/2007

William D. Short, Balderston Drive, Exton PA, USA

Specific Topic: #20 original thought, Side View of Inverted Spin Theory.

Exhibit: Section A -28 – B

Date: 11/2/2007

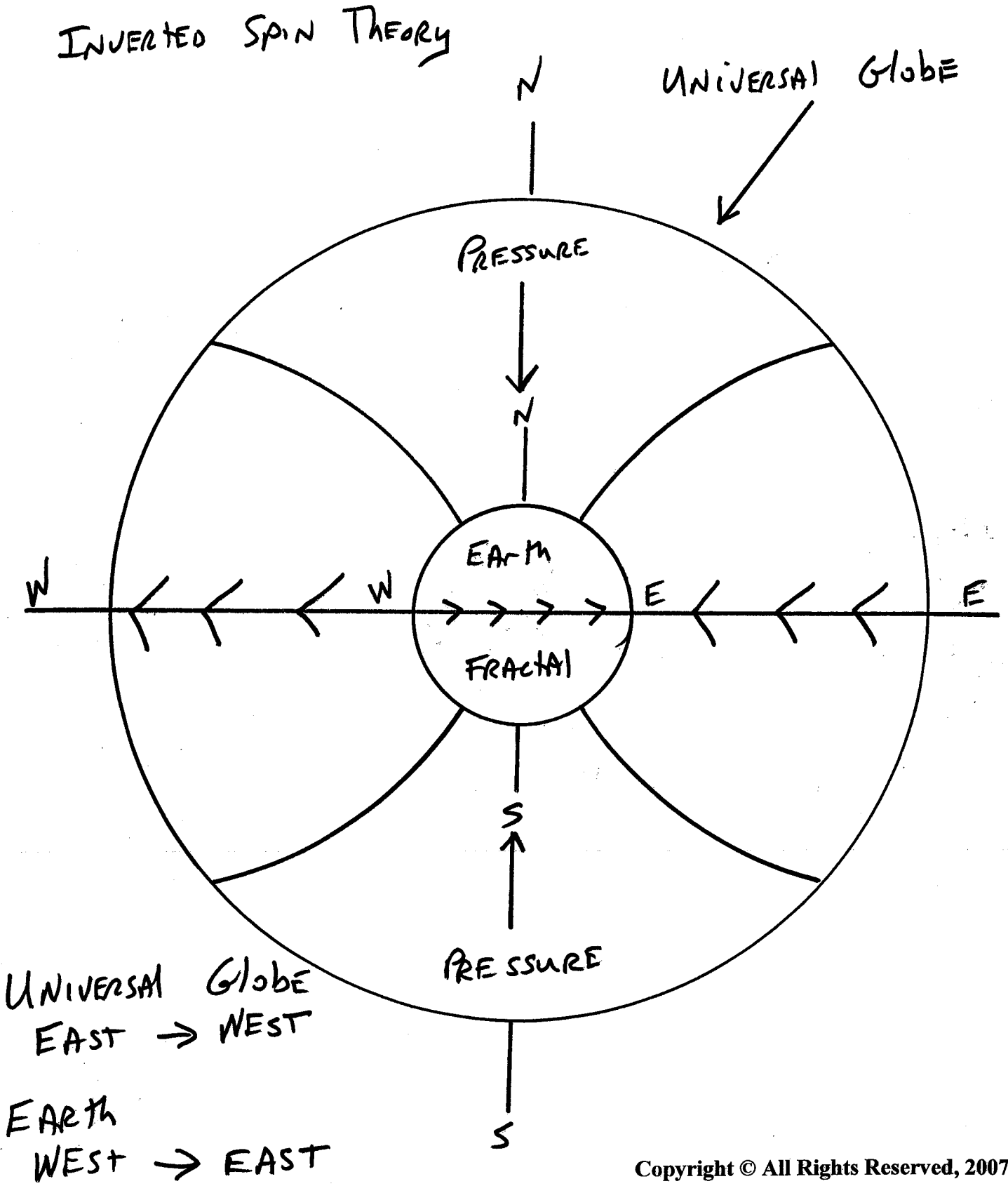

Gravity: Inverted Universal Globe Spin Theory – 10/28/2007

William D. Short, Balderston Drive, Exton PA, USA

Specific Topic: #21 original thought, In Open Space you will find No Spin and you will find No Gravity.

Exhibit: Section A – 28 – C

Date: 11/2/2007

This illustration seeks to make the obvious point. In the absence of a Planet, or a Sun traveling in the opposite direction or even the same direction within a Universal Globe you have no gravity “Inward or Outward”.

Gravity inward or outward requires a mass spinning or rotation in order to be created and maintained any type of gravity. An “Inward Directed Center of Gravity” requires not only a spinning inversion be in place, (one system rotating “counterclockwise” and the other system rotating “clockwise”) but it also requires that one of the objects be placed or found inside the other.

Copyright © All Rights Reserved, 2007

Gravity: Inverted Universal Globe Spin Theory – 10/28/2007

William D. Short, Balderston Drive, Exton PA, USA

Specific Topic: #21 original thought, In Open Space you will find No Spin and you will find No Gravity.

Exhibit: Section A – 28 – C

Date: 11/2/2007

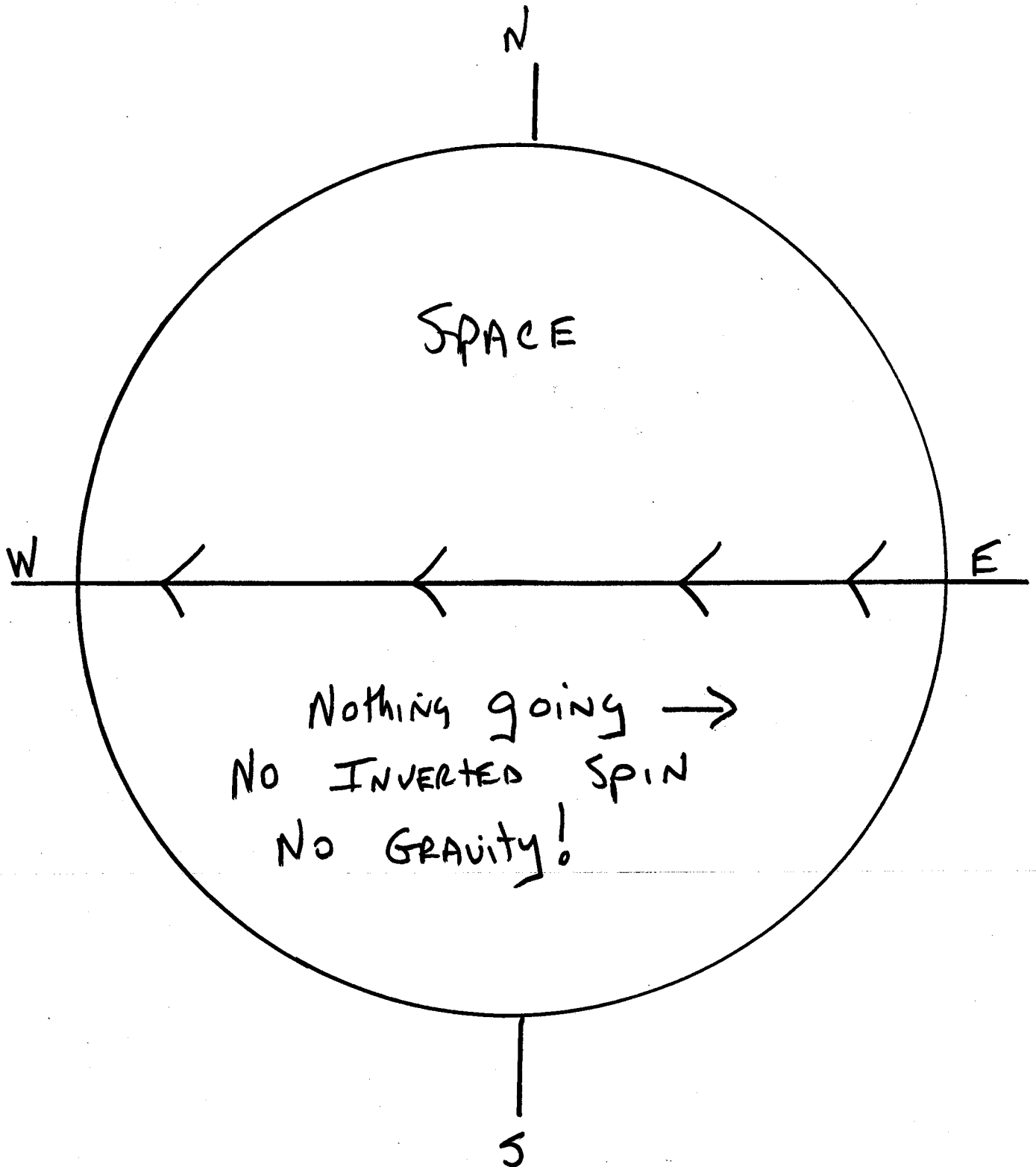

Gravity: Inverted Universal Globe Spin Theory – 10/28/2007

William D. Short, Balderston Drive, Exton PA, USA

Specific Topic: #22 original thought, Golden Spirals all around us.

Exhibit: Section A – 30 – A

Date: 11/4/2007

This illustrates another leap, a potential way in which gravity rotates. A leap based upon things we already know on Earth.

The idea here is that the center of gravity which is created and maintained thru an inverted rotation (the Earth is rotating from the West into the East, and the Universal Globe is rotating from the East into the West) may be rotating by way of what many refer to as the “Golden Spiral”.

The “Golden Spiral” is very unique in that “the spiral proceeds infinitely in both the outward and inward directions”. If this were to be taking place here on Earth then the “Inward Directed Pulling Force” from both the North Pole and the South Pole would never actually meet! And which is just the type of system one would want if one were trying to create and maintain a system that would last for a period of time.

It may just be that as we rotate inside this Universal Globe the gravitational activity may be describes best as a “Golden Spiral Inward Directed Center of Gravity”, where the top down spins and the bottom up spins but they never actually ever meet as they both come in opposite ways to the same point.

When you see the Golden Spiral though out our Plane and Universe taking place a reasonable person, especially given its properties, would make the assertion that it must be considered.

Copyright © All Rights Reserved, 2007

Gravity: Inverted Universal Globe Spin Theory – 10/28/2007

William D. Short, Balderston Drive, Exton PA, USA

Specific Topic: #22 original thought, Golden Spirals all around us.

Exhibit: Section A – 30 – A

Date: 11/4/2007

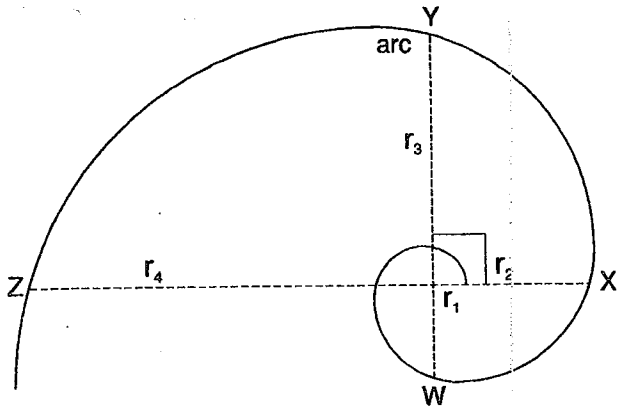

$$\frac{r_2}{r_1} = \frac{r_3}{r_2} = \frac{r_4}{r_3} = \dots = \frac{r_n}{r_{n-1}} = 1.618$$

$$\frac{d_2}{d_1} = \frac{d_3}{d_2} = \dots = \frac{d_n}{d_{n-1}} = 1.618$$

(where $d_1 = r_1 + r_3$, $d_2 = r_2 + r_4$, etc.)

$$\frac{\text{arcXY}}{\text{arcWX}} = \frac{\text{arcYZ}}{\text{arcXY}}, \text{ etc.} = \frac{\text{arcXZ}}{\text{arcWY}} = 1.618$$

$$\frac{\text{arcWY}}{\text{diam. (WY)}} = \frac{\text{arcXZ}}{\text{diam. (XZ)}}, \text{ etc.} = 1.618$$

Figure 3-8



Atomic Particles in Bubble Chamber

The Golden Spiral, which is a type of logarithmic, or equiangular, spiral, has no boundaries and is a constant shape. From any point along it, the spiral proceeds infinitely in both the outward and inward directions. The center is never met, and the outward reach is unlimited. The core of the logarithmic spiral, if viewed through a microscope, would have the same look as its expansion would from light years away.

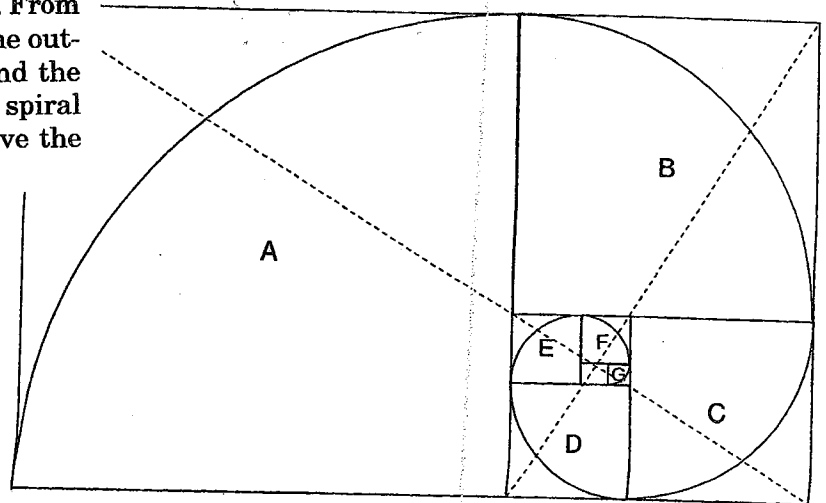
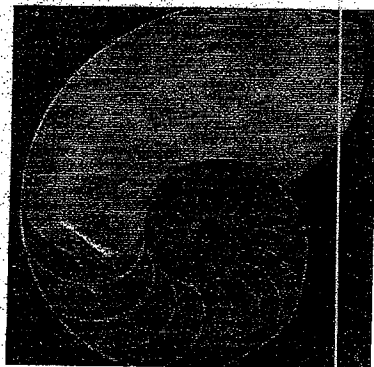

Figure 3-7



Nautilus

At any point in the evolution of the Golden Spiral, the ratio of the length of the arc to its diameter is 1.618. The diameter and radius, in turn, are related by 1.618 to the diameter and radius 90° away, as illustrated in Figure 3-8.

Gravity: Inverted Universal Globe Spin Theory – 10/28/2007

William D. Short, Balderston Drive, Exton PA, USA

Specific Topic: #22 original thought, Golden Spiral, examples in our Universe and Planet

Exhibit: Section A – 30 – B

Date: 11/4/2007

This illustrates the fact that the “Golden Spiral” is found in and though out our Planet and in and though out our Universe.

It is found though out our Earth, for example it is found in Spiraled Flowers, Shells and many other places. It is also found in the Universe, for example in the observations of Galaxies. Therefore it is hardly a reach to logically consider the “Golden Spiral” as part of the equation.

Copyright © All Rights Reserved, 2007

